

Wood-based panels — Determination of formaldehyde release —

Part 1: Formaldehyde emission by the chamber method

The European Standard EN 717-1:2004 has the status of a
British Standard

ICS 79.060.01

National foreword

This British Standard is the official English language version of EN 717-1:2004. It supersedes DD ENV 717-1:1999 which is withdrawn.

The UK participation in its preparation was entrusted to Technical Committee B/541, Wood-based panels, which has the responsibility to:

- aid enquirers to understand the text;
- present to the responsible international/European committee any enquiries on the interpretation, or proposals for change, and keep UK interests informed;
- monitor related international and European developments and promulgate them in the UK.

A list of organizations represented on this committee can be obtained on request to its secretary.

Cross-references

The British Standards which implement international or European publications referred to in this document may be found in the *BSI Catalogue* under the section entitled “International Standards Correspondence Index”, or by using the “Search” facility of the *BSI Electronic Catalogue* or of British Standards Online.

This publication does not purport to include all the necessary provisions of a contract. Users are responsible for its correct application.

Compliance with a British Standard does not of itself confer immunity from legal obligations.

Summary of pages

This document comprises a front cover, an inside front cover, the EN title page, pages 2 to 31 and a back cover.

The BSI copyright notice displayed in this document indicates when the document was last issued.

Amendments issued since publication

Amd. No.	Date	Comments

This British Standard was published under the authority of the Standards Policy and Strategy Committee on 29 September 2005

© BSI 29 September 2005

ISBN 0 580 46609 4

English version

Wood-based panels - Determination of formaldehyde release - Part 1: Formaldehyde emission by the chamber method

Panneaux à base de bois - Détermination du dégagement
de formaldéhyde - Partie 1 : Emission de for-maldéhyde
par la méthode à la chambre

Holzwerkstoffe - Bestimmung der Formaldehydabgabe -
Teil 1: Formaldehydabgabe nach der Prüfkammer-Methode

This European Standard was approved by CEN on 16 August 2004.

CEN members are bound to comply with the CEN/CENELEC Internal Regulations which stipulate the conditions for giving this European Standard the status of a national standard without any alteration. Up-to-date lists and bibliographical references concerning such national standards may be obtained on application to the Central Secretariat or to any CEN member.

This European Standard exists in three official versions (English, French, German). A version in any other language made by translation under the responsibility of a CEN member into its own language and notified to the Central Secretariat has the same status as the official versions.

CEN members are the national standards bodies of Austria, Belgium, Cyprus, Czech Republic, Denmark, Estonia, Finland, France, Germany, Greece, Hungary, Iceland, Ireland, Italy, Latvia, Lithuania, Luxembourg, Malta, Netherlands, Norway, Poland, Portugal, Slovakia, Slovenia, Spain, Sweden, Switzerland and United Kingdom.



EUROPEAN COMMITTEE FOR STANDARDIZATION
COMITÉ EUROPÉEN DE NORMALISATION
EUROPÄISCHES KOMITEE FÜR NORMUNG

Management Centre: rue de Stassart, 36 B-1050 Brussels

Contents

	Page
Foreword.....	3
Introduction	4
1 Scope	5
2 Normative references	5
3 Terms and definitions	5
4 Principle.....	6
5 Reagents	6
5.1 General.....	6
5.2 Acetylacetone solution	6
5.3 Ammonium acetate solution.....	6
5.4 Formaldehyde standard solution	6
6 Apparatus	7
6.1 Test chamber.....	7
6.2 Air sampling system.....	8
6.3 Equipment for chemical analysis.....	8
6.4 Equipment for verification of air exchange rate	9
7 Test pieces	9
8 Procedure	9
8.1 Test conditions	9
8.2 Verification of test conditions	9
8.3 Chamber preparation	10
8.4 Preparation of test pieces	11
8.5 Loading and starting procedure.....	11
8.6 Air sampling and analysis	11
8.7 Test duration	12
9 Determination of formaldehyde emission	12
9.1 General.....	12
9.2 Principle.....	12
9.3 Procedure	12
9.4 Calibration curve.....	12
9.5 Calculation of the amount of absorbed formaldehyde	13
9.6 Calculation of the formaldehyde emission	14
10 Determination of test result	14
11 Expression of results	14
12 Test report	14
Annex A (normative) Test chambers	17
Annex B (normative) Determination of air exchange rate	24
Annex C (normative) Determination of the steady-state emission value	26
Annex D (informative) Analytical procedure for the fluorimetric determination of formaldehyde content	29
Bibliography	31

Foreword

This document (EN 717-1:2004) has been prepared by Technical Committee CEN/TC 112 “Wood-based panels”, the secretariat of which is held by DIN.

This European Standard shall be given the status of a national standard, either by publication of an identical text or by endorsement, at the latest by April 2005, and conflicting national standards shall be withdrawn at the latest by April 2005.

This document supersedes ENV 717-1:1998.

Compared to ENV 717-1:1998 the following modifications have been made.

- a) Conditions for a reduced test period have been specified in Clause 10.
- b) The requirements for the air-tightness of the test chamber in 8.2.2 have been changed.

This European Standard is one of a series, which specifies methods for determining formaldehyde potential in or formaldehyde release from wood-based panels. The other standards of this series are:

EN 120, *Wood based panels — Determination of formaldehyde content — Extraction method called the perforator method.*

EN 717-2, *Wood-based panels — Determination of formaldehyde release — Part 2: Formaldehyde release by the gas analysis method.*

EN 717-3, *Wood-based panels — Determination of formaldehyde release — Part 3: Formaldehyde release by the flask method.*

This European Standard is based on CEN report CR 213 “Particleboards — Determination of Formaldehyde Emission under Specified Conditions” and COST Project 613: Indoor Air Quality and its Impact on Man, Report No. 2: “Formaldehyde emission from wood-based materials: Guideline for the determination of steady state concentrations in test chambers”.

This document includes a Bibliography.

According to the CEN/CENELEC Internal Regulations, the national standards organizations of the following countries are bound to implement this European Standard: Austria, Belgium, Cyprus, Czech Republic, Denmark, Estonia, Finland, France, Germany, Greece, Hungary, Iceland, Ireland, Italy, Latvia, Lithuania, Luxembourg, Malta, Netherlands, Norway, Poland, Portugal, Slovakia, Slovenia, Spain, Sweden, Switzerland and United Kingdom.

Introduction

Each testing institute is responsible for the quality of the test procedure. To ensure the reproducibility of the test results, it is recommended to participate in a round-robin test for calibration at least once a year.

1 Scope

This European Standard specifies a chamber method with three options of test chambers for the determination of the formaldehyde emission from wood-based panels in terms of the steady-state concentration in a climate chamber under defined conditions, which relate to typical conditions in real-life. This chamber method can also be applied to the estimation of formaldehyde concentrations under various conditions in practice, by the use of mathematical models.

This standard can also be used for the testing of formaldehyde emissions of products other than wood-based panels.

2 Normative references

The following referenced documents are indispensable for the application of this document. For dated references, only the edition cited applies. For undated references, the latest edition of the referenced document (including any amendments) applies.

EN 326-1, *Wood-based panels — Sampling, cutting and inspection — Part 1: Sampling and cutting of test pieces and expression of test results.*

3 Terms and definitions

For the purposes of this European Standard, the following terms and definitions apply.

3.1

volume of the chamber

total air volume of the unloaded chamber, including recirculating ventilation ducts, expressed in cubic metres (m^3)

3.2

loading factor

ratio of the total surface area of the test piece, excluding the area of the edges, to the volume of the chamber, expressed in square metres per cubic metre (m^2/m^3)

3.3

air exchange rate

quotient of air volume passing through the chamber per hour (m^3/h) and the chamber volume (m^3)

3.4

air velocity

velocity of the air near the surface of test pieces in the chamber in metres per second (m/s)

3.5

steady-state

state when the formaldehyde emission of the wood-based panels is quasi constant under the test conditions, this means that the formaldehyde concentration in the chamber remains constant

NOTE In practice, a true steady-state is not achievable because formaldehyde is emitted irreversibly. This standard defines a steady-state condition for the purpose of the test (see Clause 10).

3.6

emission value

the steady-state formaldehyde concentration in the chamber, obtained under constant temperature, relative humidity, loading factor and air exchange rate, expressed by mass to volume in milligrams formaldehyde per cubic metre air (mg/m^3)

NOTE At 23 °C and 1 013 hPa, the following relationship exists for formaldehyde:

1 ppm (parts per million) = 1,24 mg/m^3

1 mg/m^3 = 0,81 ppm (parts per million)

4 Principle

Test pieces of known surface area, are placed in a chamber, in which the temperature, relative humidity, air velocity and exchange rate are controlled at defined values. Formaldehyde emitted from the test pieces mixes with the air in the chamber. The air in the chamber is sampled periodically. The formaldehyde concentration is determined by drawing air from the chamber through gas washing bottles containing water, which absorbs the formaldehyde. The formaldehyde concentration in the water is determined. The concentration of formaldehyde in the chamber atmosphere is calculated from the concentration in the water in the gas washing bottles and the volume of the sampled air. It is expressed in milligrams per cubic metre (mg/m^3). Sampling is periodically continued until the formaldehyde concentration in the chamber has reached a steady-state.

NOTE The influences of temperature, relative humidity, loading factor and air exchange rate on the formaldehyde concentration in the chamber atmosphere can be described by formulas (e.g. Andersen formula). An interrelation between the structure of the test pieces, especially of their surfaces and the air velocity is also apparent but cannot be exactly described by a formula.

5 Reagents

5.1 General

Reagents and water of recognised analytical purity shall be used for the analysis.

5.2 Acetylacetone solution

4 ml acetylacetone are added to a 1 000 ml volumetric flask and made up to the mark with water.

5.3 Ammonium acetate solution

200 g ammonium acetate are dissolved in water in a 1 000 ml volumetric flask and made up to the mark.

NOTE Commercially prepared solutions may be used.

5.4 Formaldehyde standard solution

Standard iodine solution $c(\text{I}_2) = 0,05 \text{ mol/l}$

Standard sodium thiosulphate solution $c(\text{Na}_2\text{S}_2\text{O}_3) = 0,1 \text{ mol/l}$

Standard sodium hydroxide solution $c(\text{NaOH}) = 1 \text{ mol/l}$

Standard sulphuric acid solution $c(\text{H}_2\text{SO}_4) = 1 \text{ mol/l}$

6 Apparatus

6.1 Test chamber

6.1.1 General

This standard applies to different test chambers for formaldehyde emission testing which are described in Annex A.

General specifications and requirements which apply to all types of test chambers included in this standard are given in 6.1.2 to 6.1.8.

6.1.2 Test chamber materials

Materials used for the inner walls and ducts of test chambers shall have a smooth surface, which, prior to testing, can be effectively cleaned with water. The surface shall be as inert and non-absorptive as possible to formaldehyde.

NOTE Proven materials are stainless steel or aluminium (sandblasted or polished), glass and some types of plastics (PVC, PMMA).

6.1.3 Air-tightness of the chamber

The test chamber shall be air-tight in order to avoid uncontrolled air exchange.

The criteria of air-tightness are given in 8.2.2.

6.1.4 Air circulation in the test chamber

The test chamber shall contain facilities (such as fan systems) capable of maintaining:

- intensive air mixing in the chamber;
- an air velocity of 0,1 m/s to 0,3 m/s at the surface of the test pieces (see 8.2.5).

6.1.5 Air exchange facilities

The test chamber shall contain air inlet and/or outlet facilities capable of regulating the air flow and thus the rate of air exchange (replacement of chamber air by clean, conditioned air) with an error limit of 5 % at an air exchange rate of 1/h.

Precautions shall be taken to ensure that the clean air inlet and the air circulation system are adequately placed to ensure sufficient mixing and that ambient air cannot enter into the air outlet, even during sampling.

6.1.6 Clean air supply of the test chamber

Equipment capable of providing clean air with a maximum formaldehyde content of 0,006 mg/m³ (0,005 ppm).

6.1.7 Temperature and relative humidity regulating systems

Equipment capable of maintaining the temperature and the relative humidity in the test chamber within the following limits:

- Temperature: $(23 \pm 0,5)$ °C
- Relative humidity: (45 ± 3) %

6.1.8 Equipment for monitoring of test conditions

Measuring equipment and recording facilities capable of continuous or frequent monitoring of the specified test conditions with an error limit as follows:

- Temperature: 0,1 °C
- Relative humidity: 1 %
- Air exchange rate: 0,03/h
- Air velocity: 0,05 m/s

6.2 Air sampling system

6.2.1 General

Figure 1 shows the principle of a sampling system for the determination of the formaldehyde concentration in the chamber air. The sampling tube shall be placed either in the air outlet, or inside the chamber, close to the air outlet.

NOTE Other sampling systems may be used, provided it can be shown that they give equivalent results.

6.2.2 Equipment

6.2.2.1 General

The air sampling system consists of the following components which are given in Figure 1. The numbers in brackets refer to the numbers in Figure 1:

6.2.2.2 Sampling tube (1)

6.2.2.3 Two 100 ml gas washing bottles, containing water, for absorption and subsequent determination of formaldehyde (2)

6.2.2.4 Silica absorber for drying the air (3)

6.2.2.5 Gas flow valve (4)

6.2.2.6 Gas sampling pump (5)

6.2.2.7 Gas flow meter (6)

6.2.2.8 Gas meter (including a thermometer) for measuring the volume of air (7)

6.2.2.9 Air pressure meter (8)

6.3 Equipment for chemical analysis

6.3.1 Spectrophotometer, suitable for use with cells with a path-length of at least 50 mm and capable of measuring absorbance at 412 nm

- 6.3.2 Water bath, capable of maintaining a temperature of (40 ± 1) °C
- 6.3.3 Six volumetric flasks, 100 ml (calibrated at 20 °C)
- 6.3.4 Two volumetric flasks, 1 000 ml (calibrated at 20 °C)
- 6.3.5 Bulb pipettes, 5 ml, 10 ml, 15 ml, 20 ml, 25 ml, 50 ml, and 100 ml (calibrated at 20 °C)
- 6.3.6 Microburette
- 6.3.7 At least three flasks, 50 ml, with stoppers
- 6.3.8 Balance, scale interval 0,001 g

6.4 Equipment for verification of air exchange rate

- 6.4.1 Compressed-gas cylinder with tracer-gas
- 6.4.2 Detector for continuous monitoring of tracer-gas
- 6.4.3 Recorder

NOTE Dinitrogen monoxide (N₂O) with infrared (IR) detection has proved to be suitable.

7 Test pieces

Sample the test pieces according to the general principles of EN 326-1 and cut them to a size which corresponds to a total loading rate of 1 m²/m³ (see Annex A). Wrap the test pieces hermetically immediately after cutting and leave them wrapped until the start of the test.

8 Procedure

8.1 Test conditions

The following conditions shall be maintained in the chamber throughout the test:

- Temperature $(23 \pm 0,5)$ °C;
- Relative humidity (45 ± 3) %;
- Loading factor $(1,0 \pm 0,02)$ m²/m³;
- Air exchange rate $(1,0 \pm 0,05)$ /h;
- Air velocity at the surface of the test pieces (see 8.2.5) $(0,1$ to $0,3)$ m/s.

8.2 Verification of test conditions

8.2.1 Clean air supply of the test chamber

When determined in accordance with Clause 9, the formaldehyde content of the air supplied to the chamber shall not exceed 0,006 mg/m³ (0,005 ppm).

8.2.2 Air-tightness of the test chamber

In order to avoid uncontrolled air exchange by intrusion of ambient air, the test chamber shall be operated at a slight over-pressure.

Air-tightness shall be checked regularly, either by pressure drop measurements or by comparison of simultaneous measurement of flow rates at the inlet and the outlet ports, or by measuring tracer gas dilution.

The test chamber is considered sufficiently air-tight if at least one of the following requirements is fulfilled:

- the air leakage is less than $10^{-2} \times$ chamber volume per minute at an overpressure of 1 000 Pa;
- the inlet and outlet air flow differ by less than 2 %;
- the tracer gas dilution is less than 0,05/h.

8.2.3 Temperature and relative humidity control system

The temperature shall be controlled either by placing the test chamber within a location controlled to the appropriate temperature, or by controlling the temperature within the chamber.

In the latter case, the chamber walls shall be insulated effectively to avoid condensation of moisture on their inner surface.

Control of relative humidity shall be made either by external humidity control of the clean air supply, or internal humidity control of the air within the chamber. In the latter case, precautions shall be taken to avoid condensation, or spray of water, inside the chamber.

Temperature and relative humidity shall be monitored either continuously, or frequently, and independently of the air conditioning system. Sensors shall be placed in a representative position inside the chamber.

After loading the chamber, any initial deviations of temperature and relative humidity due to ambient air and unconditioned test pieces shall be recorded.

8.2.4 Air exchange

The clean and conditioned air supply to the chamber shall either be monitored continuously, or frequently. Suitable methods are specified in Annex A.

The air exchange rate shall not vary by more than 0,05 exchanges of air per hour.

The effective air exchange rate shall be regularly checked, by using either a calibrated gas meter, or the tracer gas procedure described in Annex B.

8.2.5 Air velocity in the chamber

Prior to testing, the air velocity in the test chamber loaded with test pieces shall be set to a value between 0,1 m/s and 0,3 m/s, measured at representative positions not more than 20 mm from the surface of the test pieces.

NOTE Hot wire or film anemometers calibrated in the range of 0 m/s to 0,5 m/s are suitable for air velocity measurement.

The positions of the measuring points depend upon the volume of chamber and the type of air flow.

Air velocity shall be measured at a minimum of 4 positions in large chambers ($\geq 12 \text{ m}^3$) and at a minimum of 2 positions in small chambers (1 m^3 or $0,225 \text{ m}^3$).

8.2.6 Performance of the chamber

The performance of the test chamber can be tested by a procedure described by [7].

8.3 Chamber preparation

Set the chamber to the conditions given in 8.1. The determination (see 8.6) of the formaldehyde concentration in the empty chamber ("background-level") shall be carried out not less than 1 h after establishing the test conditions according to 8.1.

If the formaldehyde concentration in the chamber atmosphere is $0,006 \text{ mg/m}^3$ or lower, the chamber can be loaded with the test pieces.

If the formaldehyde concentration is higher than $0,006 \text{ mg/m}^3$, the chamber shall be purged by running empty to reduce the formaldehyde concentration to the accepted background level of $0,006 \text{ mg/m}^3$. If necessary, dust and other particles from the bottom shall be removed and the walls and other interior surfaces of the chamber shall be cleaned before starting the air cleaning procedure.

8.4 Preparation of test pieces

8.4.1 General

Unwrap the test pieces, seal the edges if necessary and place the test pieces in the chamber. The ratio of the length of open (unsealed) edges U related to the surface area A shall be $U/A = 1,5 \text{ m/m}^2$.

NOTE As a result of the constant ratio $U/A = 1,5 \text{ m/m}^2$ the percentage of open edges area related to the surface area depends on the thickness of the test piece, as shown in the following examples:

Panel thickness	Ratio of the open edge area to total surface area
10 mm	1,5 %
19 mm	2,8 %
32 mm	4,8 %

8.4.2 Large chambers (see A.1)

Edge sealing shall not be done for the $1 \text{ m} \times 2 \text{ m}$ test pieces tested in large chambers ($\geq 12 \text{ m}^3$). The perimeter, i. e. the length of open (unsealed) edges U for $1 \text{ m} \times 2 \text{ m}$ pieces is 6 m and the surface area A is 4 m^2 . Thus the ratio of U/A is $1,5 \text{ m/m}^2$.

8.4.3 Small chambers (see A.2 and A.3)

In order to obtain the same ratio of $U/A = 1,5 \text{ m/m}^2$ for smaller test pieces in small chambers, partial edge sealing is necessary. This sealing should be done using self-adhesive aluminium tape.

NOTE The length of edges to be sealed is given in A.2.3 for 1 m^3 chambers and in A.3.3 for $0,225 \text{ m}^3$ chambers.

8.5 Loading and starting procedure

Place the test pieces in the test chamber. They shall be vertical and approximately in the centre of the chamber, with their surfaces parallel to the direction of the air flow, and separated by not less than 200 mm (see Figures A.1 to A.5 and A.7). The first air sampling shall be made not less than 3 h after loading the chamber and starting the test procedure.

8.6 Air sampling and analysis

Add at least 25 ml of water to each of the two gas washing bottles and connect them to the apparatus (see 6.2 and Figure 1). Sample the air from the chamber periodically by passing a minimum of 120 l, at a rate of approximately 2 l/min, through the gas washing bottles. Pipette 10 ml of each of the absorption solutions into a 50 ml flask and add 10 ml acetylacetone solution (see 5.2) and 10 ml of ammonium acetate solution (see 5.3). Stopper the flasks and determine the formaldehyde content of the solutions according to Clause 9.

NOTE The volume of air to be sampled depends on its formaldehyde concentration. With photometric determination the procedure described above is suitable for concentrations higher than $0,005 \text{ mg/m}^3$. For determination of lower concentrations, the volume of the sampled air should be increased and/or the volume of the air sample solution reduced. The sensitivity of the analysis can also be increased by using a fluorimetric determination of the reaction product (diacetyldihydrolutidine) instead of a photometric determination.

8.7 Test duration

The sampling procedure is repeated twice a day until enough data are available to calculate the steady-state (see Annex C).

The time interval between the two samplings shall be more than 3 h.

9 Determination of formaldehyde emission

9.1 General

The formaldehyde content of the aqueous solutions from each sampling period shall be determined photometrically by the acetylacetone method.

NOTE 1 To enhance the sensitivity of the analysis, the formaldehyde content can also be determined fluorimetrically (procedure see Annex D).

NOTE 2 The determination according to ISO 16000-3 (DNPH) can also be used.

9.2 Principle

The determination is based on the Hantzsch reaction in which formaldehyde reacts with ammonium ions and acetylacetone to yield diacetyldihydropyridine (DDL) (see Figure 2). DDL has an absorption maximum at 412 nm. The reaction is specific to formaldehyde.

9.3 Procedure

Heat the stoppered flasks (see 8.6) for 15 min in a water bath at (40 ± 1) °C. The solutions are then stored at room temperature for 1 h, protected against the influence of light. The absorbance of the solutions is determined at a wavelength of 412 nm against water, using a spectrophotometer with a cell of 50 mm path-length (see 6.3.1).

A blank value is determined in parallel, using a solution made up of 10 ml water, 10 ml acetylacetone solution (see 5.2) and 10 ml ammonium acetate solution (see 5.3) and is taken into consideration when calculating the formaldehyde content of the sample solution.

NOTE Cells with greater path-length can be used, but will give different calibration curves and in this case a modified evaluation procedure is necessary.

9.4 Calibration curve

9.4.1 General

The calibration curve (see Figure 3) is produced from a standard formaldehyde solution, the concentration of which has been determined by iodometric titration. This calibration curve shall be checked at least once a week.

9.4.2 Formaldehyde standard solution

Reagents:

Standard iodine solution $c(I_2) = 0,05$ mol/l

Standard sodium thiosulphate solution $c(Na_2S_2O_3) = 0,1$ mol/l

Standard sodium hydroxide solution $c(NaOH) = 1$ mol/l

Standard sulphuric acid solution $c(H_2SO_4) = 1$ mol/l

The above solutions shall be standardized before use

— starch solution 1 % by mass

Dilute about 1 g formaldehyde solution (concentration 35 % to 40 %) with water in a 1 000 ml volumetric flask and make up to the mark. Determine the exact formaldehyde concentration as follows:

Mix 20 ml of the formaldehyde standard solution with 25 ml iodine solution and 10 ml sodium hydroxide solution. After 15 min standing protected from light add 15 ml of sulphuric acid solution. Tritrate back the excess iodine with the sodium thiosulphate solution. Near the end of the titration add some drops of the starch solution as an indicator. Carry out in parallel a blank test with 20 ml of water.

The formaldehyde content is calculated as follows:

$$c(\text{HCHO}) = (V_0 - V) \times 15 \times c(\text{Na}_2\text{S}_2\text{O}_3) \times 1\,000/20 \quad (1)$$

where:

$c(\text{HCHO})$ is the formaldehyde concentration, in milligrams per litre;

V is the volume of the consumed thiosulphate titration solution, in millilitres;

V_0 is the volume of the consumed thiosulphate titration solution for blank titration, in millilitres;

$c(\text{Na}_2\text{S}_2\text{O}_3)$ is the thiosulphate concentration, in mols per litre.

NOTE 1 1 ml of 0,1 mol/l thiosulphate corresponds to 1 ml of 0,05 mol/l iodine solution and 1,5 mg formaldehyde.

NOTE 2 With digital/automatic pipettes the volumes of the solutions can be reduced provided they give the same results.

9.4.3 Formaldehyde calibration solution

Using the concentration value determined in 9.4.2, calculate the volume of the formaldehyde solution which will contain about 3 mg formaldehyde. Transfer this volume, using a microburette, to a 1 000 ml volumetric flask and make up to the mark with water. 1 ml of this calibration solution contains about 3 µg formaldehyde.

9.4.4 Determination of the calibration curve

Pipette 0 ml, 5 ml, 10 ml, 20 ml, 50 ml and 100 ml of formaldehyde calibration solution (see 9.4.3) into a 100 ml volumetric flask and make up to the mark with water. 10 ml of each dilution are analysed photometrically by the same procedure as described in 9.3. The absorbance values are plotted against the formaldehyde concentrations c (between 0 and 0,003 mg/ml, see example in Figure 3). The slope f of the graph is either determined graphically, or calculated.

9.5 Calculation of the amount of absorbed formaldehyde

The amount of formaldehyde absorbed in the water of the gas washing bottles is calculated by the following equation:

$$G = (A_s - A_b) \times f \times V_{\text{sol}} \quad (2)$$

where:

G is the amount of formaldehyde in each of the trapping solutions, in milligrams;

A_s is the absorbance of the solution from the gas washing bottle;

A_b is the absorbance of the blank value (see 9.3);

f is the slope of the calibration curve for the standard formaldehyde solution, in milligrams per millilitre;

V_{sol} is the volume of the trapping solution, in millilitres.

The values of G from both trapping solutions are added to give the total amount of formaldehyde G_{tot} .

9.6 Calculation of the formaldehyde emission

The formaldehyde emission from the wood-based panels being tested is expressed as the concentration in the air of the test chamber and is calculated by the following equation:

$$c = G_{\text{tot}}/V_{\text{air}} \quad (3)$$

where:

c is the formaldehyde concentration, in milligrams per cubic metre;

G_{tot} is the total amount of formaldehyde trapped, in milligrams;

V_{air} is the volume of the air sample, in cubic metres.

NOTE The volume of the sampled air should be corrected to a standard temperature of 23 °C and a standard air pressure of 1 013 hPa.

10 Determination of the steady-state emission value

The steady-state emission value is calculated using the procedure given in Annex C. For this calculation, the minimum duration of the chamber test is fixed to 10 days and a measurement of the formaldehyde concentration is carried out on at least 7 days (not necessarily consecutive days). A minimum of two formaldehyde determinations per day is needed. The steady-state is reached when the decline of the calculated concentration curve is equal to or lower than 5 % over a testing time of 4 days ($\delta = 0,05$, see Annex C). If this condition is not reached within 10 days, the test shall be continued. If the steady-state condition is not reached within 28 days (672 h), the value calculated by the complete power function for the 28th day of the test is defined as the steady-state emission value.

The test may be stopped after a minimum of four testing days, providing that no test result on four successive days exceeds the threshold value, taking the accuracy of the test method into account, and the linear regression function from the four daily test values shows an increase of not more than 2 $\mu\text{g}/\text{m}^3$.

11 Expression of results

The steady-state emission value is expressed in milligrams per cubic metre (mg/m^3) rounded to the next 0,01 mg/m^3 . The test duration (in hours) to establish the steady-state emission value shall be indicated in brackets after the value.

If the test is stopped prematurely, the test result is given as the mean value of the measurements taken on the last day of the test.

NOTE A round-robin test with several European test institutes has shown standard deviations for different test materials varying between 14 % (high emitting material) and 20 % (low emitting material).

12 Test report

The test report shall be in accordance with EN 326-1. Additionally, the test report shall include the following information. If any of the information listed under points a) to g) inclusive is not available, this shall be recorded:

- a) Type of the chamber (option);
- b) If appropriate and known, the name of the producer, the date and place of production, the manner of shipment, the handling between arrival at the test laboratory and the start of the test;
- c) Date of starting and ending of the test procedure;
- d) Short description of the test conditions and the analytical procedure used;

- e) The steady-state emission value in milligrams formaldehyde per cubic metre (mg/m^3);
- f) The test duration to establish the steady state emission value;
- g) Description of further items (e. g., report on procedures which are not in line with this standard).

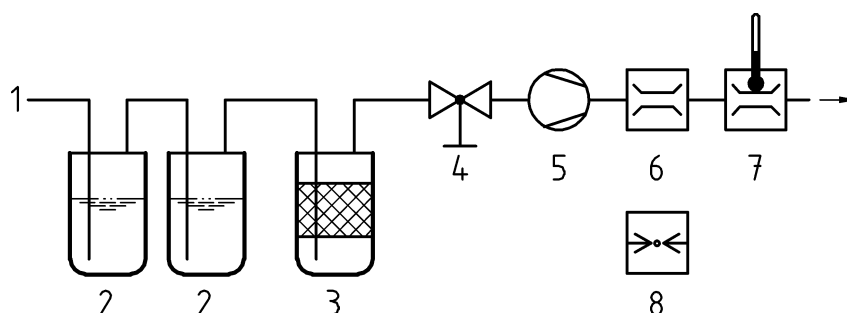
**Key**

- 1 Sampling tube
2 Gas washing bottles
3 Silica absorber
4 Gas flow valve

- 5 Gas sampling pump
6 Gas flow meter
7 Gas meter with thermometer
8 Air pressure meter

Figure 1 — Example of a sampling system for the determination of formaldehyde concentration in air

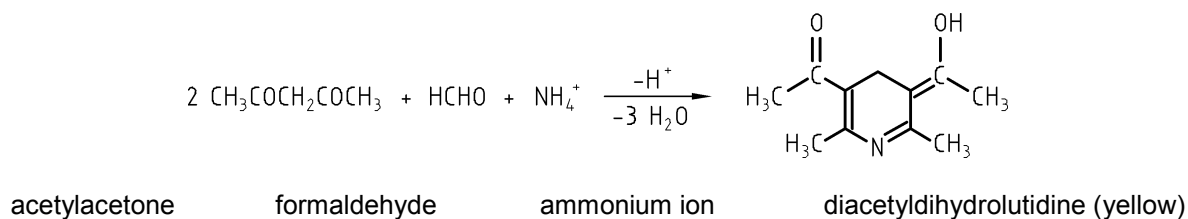
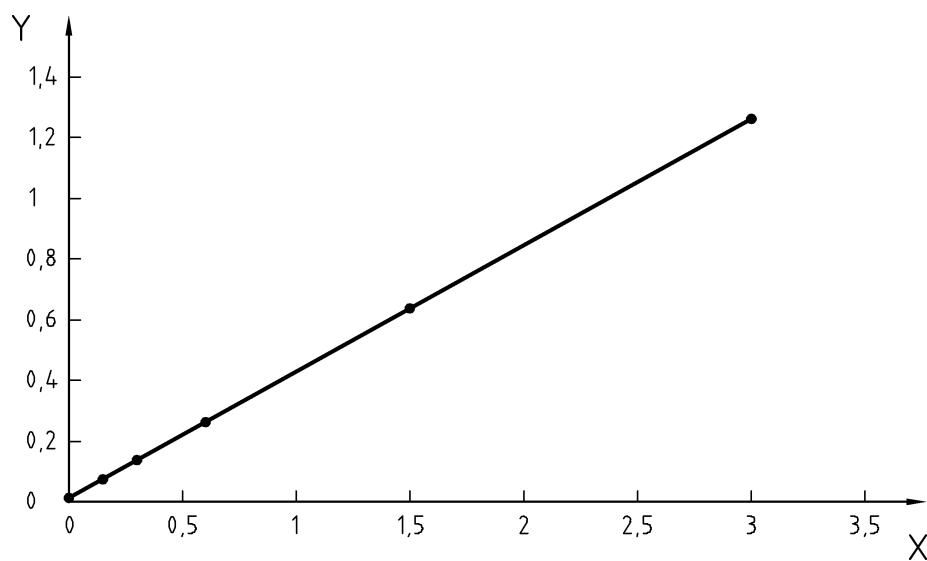

Figure 2 — Reaction scheme of the acetylacetone method



$$c = f \cdot (A_s - A_b)$$

KeyY Absorbance $A_s - A_b$ X Concentration of the diluted calibration solution c [10^{-3} mg/ml]

Figure 3 — Example of a calibration curve for formaldehyde determined by acetylacetone method (path length 50 mm)

Annex A (normative)

Test chambers

A.1 Option 1: Large test chamber

A.1.1 Chamber volume and operation

In this standard large test chambers are defined as those with a minimum net volume of 12 m³.

NOTE The net volume of the test chamber is the volume of that part of the chamber to be loaded with test pieces and, if existing, that part of the chamber used for air conditioning and air circulation.

Large chambers can be operated with two different types of air circulation:

- parallel air flow (see Figure A.1); or
- circular air flow (see Figure A.2).

The temperature and the relative humidity can be established within the chamber by special conditioning devices (air heater, steam injector) or by using preconditioned inlet air. Chambers operated in this way need effective insulation of the chamber walls.

The temperature within the test chamber can also be established by placing the chamber in a larger compartment with controlled temperature. The chambers operated in this way shall have no insulation.

The volume of the inlet air is adjusted by a ventilation or compressed air system and can be monitored by a gas flow meter in the inlet or by measuring the air velocity in the air inlet. The effective air exchange rate shall be regularly checked (see 8.2.4).

A.1.2 Construction principle

The test apparatus (see Figures A.1 and A.2) comprises the following main components (the numbers in brackets refer to the numbers in the Figures A.1 and A.2):

- a) Climate controlled test chamber (1)

Large chambers should have volumes in multiples of 4 m³ with a minimum volume of 12 m³, to permit the usage of uniform test piece sizes (1,0 m × 2,0 m × board thickness).

- b) Air inlet with air flow regulator (2)

The inlet air should be cleaned if necessary and preconditioned to near the test temperature.

- c) Ventilation fan (3)

The ventilation fan (one or more) mixes the air in the chamber by intensive circulation. The construction principle of the chamber forces air mixing atmosphere by an intensive air flow through the usable space of the chamber.

- d) Equipment for regulating temperature (4)

- e) Steam injection for controlling relative air humidity (5)

- f) Air outlet (6)

- g) Test pieces (7)
- h) Instruments and sensors for measuring and recording temperature, air humidity and air flow in the air inlet and/or air outlet

A.1.3 Test pieces

Produce and prepare test pieces in accordance with Clause 7 and 8.4. The size of the boards should be $1,0 \text{ m} \times 2,0 \text{ m} \times$ board thickness. The chamber is loaded with one board of this size per 4 m^3 chamber volume. The test pieces are positioned in the chamber as shown in Figures A.1 and A.2, parallel to the air flow, with their faces separated by a minimum distance of 200 mm.

A.2 Option 2: 1 m^3 test chamber

A.2.1 Chamber volume and operation

Chambers of this type have a total volume of 1 m^3 . 1 m^3 test chambers are operated with intensive circular air flow (see Figures A.3, A.4 and A.5).

The climatic test conditions (temperature, relative humidity) can be established within the chamber either by special conditioning devices (air heater, steam injector), or by using preconditioned inlet air. Chambers operated in this way need effective wall insulation.

The temperature within the test chamber can also be established by placing the chamber in a larger compartment with controlled temperature. Test chambers operated in this way shall have no insulation.

NOTE Figure A.6 shows an apparatus suitable to establish a relative humidity of $(45 \pm 3) \%$.

The volume of the inlet air is measured and adjusted by a gas pump or a compressed air system in connection with gas flow meters (see Figure A.6) and can be measured by a calibrated gas meter in the outlet. The effective air exchange rate shall be regularly checked (see 8.2.4).

A.2.2 Construction principle

The test apparatus comprises the following components, see Figures A.3, A.4 and A.5 (the numbers in brackets refer to the numbers in the Figures A.3, A.4 and A.5):

- a) Chamber with a total volume of $(1 \pm 0,01) \text{ m}^3$ (1)

The 1 m^3 test chambers shown in the Figures as examples are constructed from metal, glass or plastic plates.

- b) Air inlet (2)

The inlet air should be cleaned, if necessary and preconditioned to near the test temperature. The volume of the air flow through the test chamber is measured by a gas meter.

- c) Ventilation fan (at least one) (3)

The ventilation fan mixes the air in the chamber by intensive circulation.

- d) Inlet to introduce sensors for continuous or frequent monitoring of temperature and air relative humidity (4)
- e) Air outlet (5)
- f) Baffle plates, or partition, or perforated bottom
- g) Test pieces

A.2.3 Test pieces

Produce and prepare test pieces in accordance with Clause 7 and 8.4. The size of the test pieces should be $0,5\text{ m} \times 0,5\text{ m} \times$ board thickness. For this size, $1,25\text{ m}$ of the edges have to be sealed to attain the ratio $UIA = 1,5\text{ m}^2/\text{m}^2$ in accordance with 8.4; $0,75\text{ m}$ of the edges remain unsealed. The chamber is loaded with two test pieces of this size. The test pieces are positioned near to the centre of the chamber, parallel to the air flow, with their faces separated by a minimum distance of 200 mm .

A.3 Option 3: $0,225\text{ m}^3$ test chamber

A.3.1 Chamber volume and operation

This test chamber has a volume of $0,225\text{ m}^3$. The chamber is operated with circular air flow (see Figure A.7). The temperature within the test chamber is established by placing the chamber in a larger compartment with controlled temperature.

NOTE 1 For the chamber shown in Figure A.7, the temperature within the chamber is established by the temperature of the surrounding room.

The relative humidity is established by dew point control of the inlet air. Using this principle, the inlet air is cleaned within the same procedure. The relative humidity is established by moistening the inlet air to achieve the required value of $(45 \pm 3)\%$.

NOTE 2 Figure A.6 shows an apparatus suitable to establish a relative humidity of $(45 \pm 3)\%$.

The volume of the inlet air is measured and adjusted by a gas pump or a compressed air system in connection with gas flow meters (see Figure A.6) and can be measured by a calibrated gas meter in the outlet. The effective air exchange rate shall be regularly checked (see 8.2.4).

A.3.2 Construction principle

The test apparatus comprises the following components, see Figure A.7 (the numbers in brackets refer to the numbers in Figure A.7):

- a) Test chamber with a volume of $(0,225 \pm 0,0045)\text{ m}^3$ (1).

The dimensions of the chamber are $0,7\text{ m} \times 0,5\text{ m} \times 0,65\text{ m}$. The chamber is positioned in a larger conditioned room establishing a constant temperature of $(23 \pm 0,5)\text{ }^\circ\text{C}$ within the chamber.

- b) Air inlet (2)

The air inlet of the chamber is placed close to the inlet port of the fan.

- c) Ventilation fan with external electric motor (3)

The drum fan powered by an outside electric motor ensures a symmetric, circular air flow around the test pieces.

- d) Inlet to introduce sensors for continuous or frequent monitoring of temperature and air relative humidity (4).

- e) Air outlet (5)

The air outlet openings are placed far from the inlet openings. Tubes for air sampling are inserted through the outlet pipes and sampling is made close to the outlets.

- f) Test pieces (6)

A.3.3 Test pieces

Produce and prepare test pieces in accordance with Clause 7 and 8.4. The size of the test pieces should be 0,2 m × 0,28 m × board thickness. For this size, 0,792 m of the edges shall be sealed to attain the ratio $U/A = 1,5 \text{ m}^2/\text{m}^2$ in accordance with 8.4; 0,168 m of the edges remain unsealed. The chamber is loaded with two test pieces of this size. The test pieces are positioned near to the centre of the chamber, parallel to the air flow, with their faces separated by a minimum distance of 200 mm.

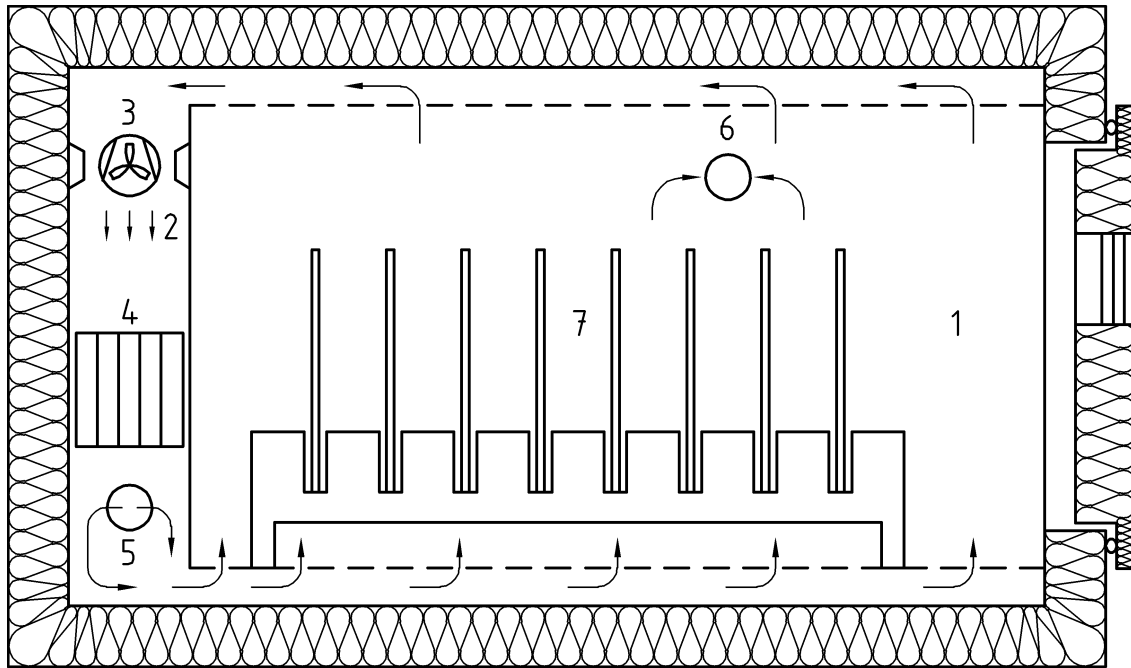

- Key**
- | | |
|--------------------------------------|--|
| 1 Test chamber | 5 Steam injection, controlling relative humidity |
| 2 Air inlet | 6 Air outlet |
| 3 Ventilation fan | 7 Test pieces |
| 4 Equipment, controlling temperature | |

Figure A.1 — Example of a construction scheme for a large test chamber with parallel air flow

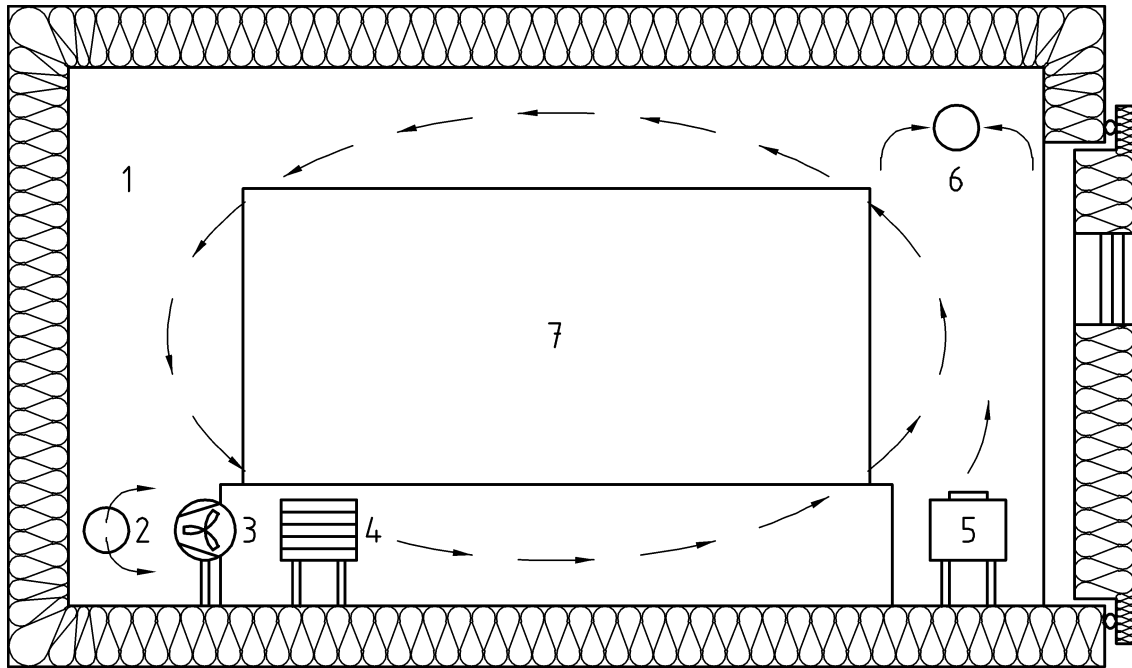

Key

- | | |
|--------------------------------------|--|
| 1 Test chamber | 5 Steam injection, controlling relative humidity |
| 2 Air inlet | 6 Air outlet |
| 3 Ventilation fan | 7 Test pieces |
| 4 Equipment, controlling temperature | |

Figure A.2 — Example of a construction scheme for a large test chamber with circular air flow

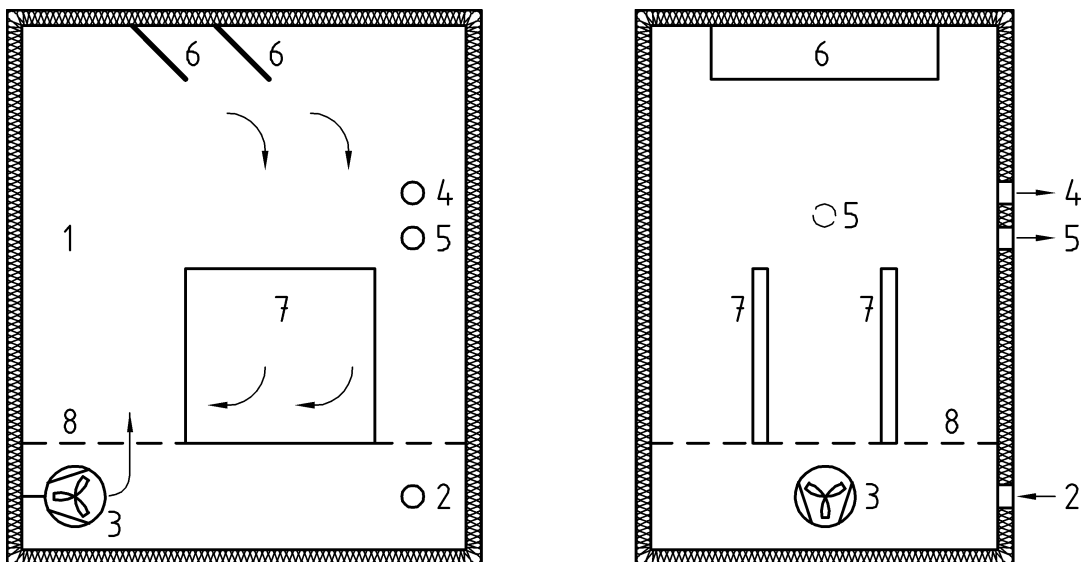

Key

- | | |
|--|---------------------|
| 1 1 m ³ test chamber | 5 Air outlet |
| 2 Air inlet | 6 Baffle plates |
| 3 Ventilation fan | 7 Test pieces |
| 4 Inlet for monitoring equipment/sensors | 8 Perforated bottom |

Figure A.3 — Example 1 of a construction scheme for a 1 m³ test chamber

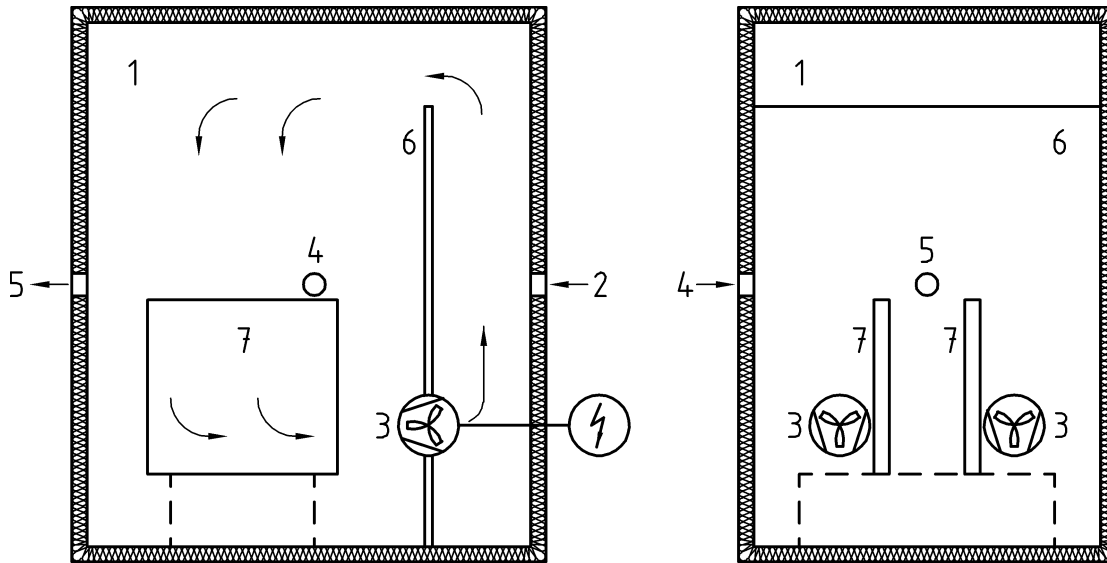

Key

- 1 1 m³ test chamber
- 2 Air inlet
- 3 Ventilation fan with electric power supply
- 4 Inlet for monitoring equipment/sensors
- 5 Air outlet
- 6 Partition
- 7 Test pieces

Figure A.4 — Example 2 of a construction scheme for a 1 m³ test chamber

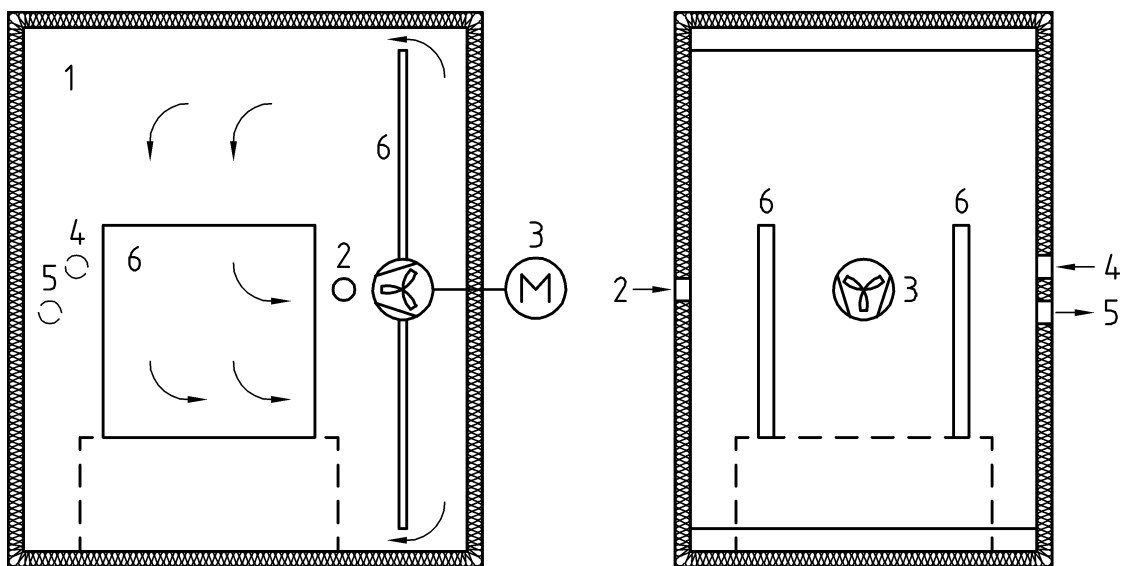

Key

- 1 1 m³ test chamber
- 2 Air inlet
- 3 Ventilation fan with external electric power
- 4 Inlet for monitoring equipment/sensors
- 5 Air outlet
- 6 Test pieces

Figure A.5 — Example 3 of a construction scheme for a 1 m³ test chamber

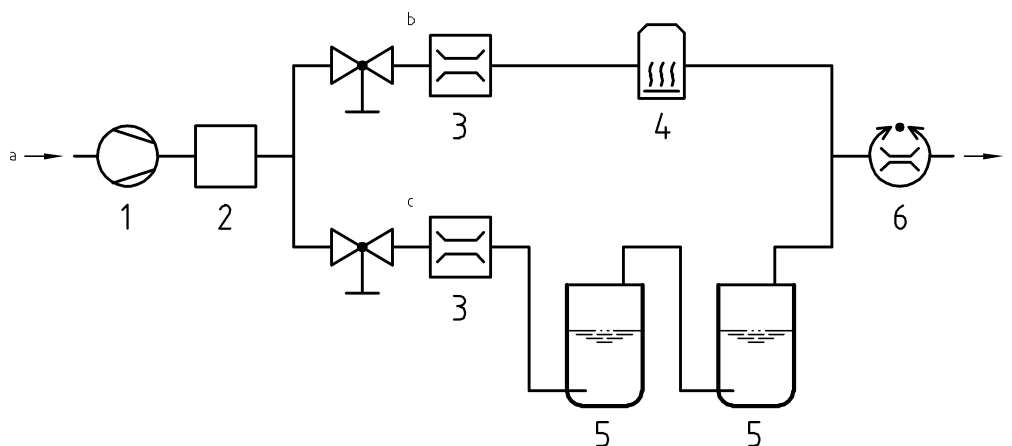

Key

- a Air (in)
- b 55 % air flow
- c 45 % air flow
- d To the chamber
- 1 Gas pump
- 2 Charcoal filter
- 3 Gas flow meter and gas flow control
- 4 Silicagel filter
- 5 Washing bottle (humidification) with a minimum volume of 1 000 ml
- 6 Flow controller or gas meter

Figure A.6 — Example of a device for establishing a controlled air flow with a relative humidity of 45 %

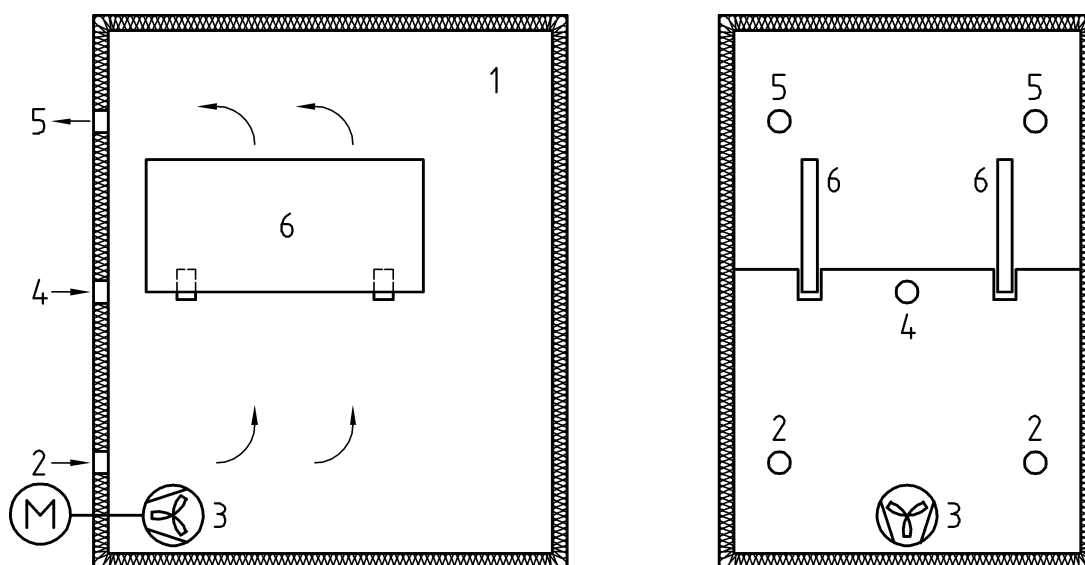

Key

- 1 0,225 m³ test chamber
- 2 Air inlet
- 3 Ventilation fan with external electric motor
- 4 Inlet for monitoring equipment/sensors
- 5 Air outlet
- 6 Test pieces

Figure A.7 — The construction scheme of the 0,225 m³ test chamber

Annex B (normative)

Determination of air exchange rate

B.1 Principle

The determination of the air exchange rate n in the unloaded test chamber is based on the method for measuring the concentration dynamics of an indicator gas (tracer gas) which is introduced into the chamber from a compressed gas cylinder. The indicator gas concentration will decrease over time depending on the air exchange rate. Under ideal air mixing conditions in the chamber, the concentration will follow the equation:

$$c_t = c_0 e^{-nt} \quad (\text{B.1})$$

$$n = (1/t) \ln (c_0/c_t) \quad (\text{B.2})$$

where:

c_0 is the initial concentration of indicator gas, in milligrams per cubic metre;

c_t is the concentration of indicator gas, in milligrams per cubic metre at time t in hours;

n is the exchange rate per hour (1/h);

t is the time, in hours.

NOTE Dinitrogen monoxide (N_2O) is a suitable tracer gas and can be determined using an infrared (IR)-detector. Dinitrogen monoxide has a molecular weight of 44,01 g/mol and a density of 1,53 relative to air.

B.2 Equipment for measurement

B.2.1 Infrared (IR) gas analyser capable of measuring dinitrogen monoxide at concentrations up to 2 000 mg/m³ with continuous on-line recorder

B.2.2 A compressed gas cylinder with reducing valve, containing N_2O

B.3 Procedure

The test chamber is operated under the test conditions described in this standard (see 8.1). For the determination of the exact air exchange rate, N_2O from a gas cylinder is introduced into the test chamber, until the maximum concentration of the measuring range chosen has nearly been reached. The N_2O /air mixture is sampled from the air outlet or a place near the air outlet of the test chamber by means of a flexible sampling tube connected to the IR gas analyser; the N_2O concentration is recorded (see Figure B.1). The concentration of N_2O in the air of the test chamber will be unstable for some minutes, afterwards it decreases continuously, following the mathematical expression given in equation (B.1).

NOTE After about 10 min the first concentration value c_0 is measured, after further 30 min the second concentration value c_t . The procedure can be repeated for other pairs of values. Also, the values can be linearized to determine the air exchange rate by the slope of the graph using equation (B.2).

B.4 Evaluation

The air exchange rate n is calculated from c_0 and c_t , for a defined period using equation (B.2). If the calculated value deviates by more than 5 % from the prescribed value 1/h, the air exchange for the test has to be adjusted and the determination procedure has to be repeated.

When reading the N_2O concentration, attention should be paid to non-linearity of the reading or recording device.

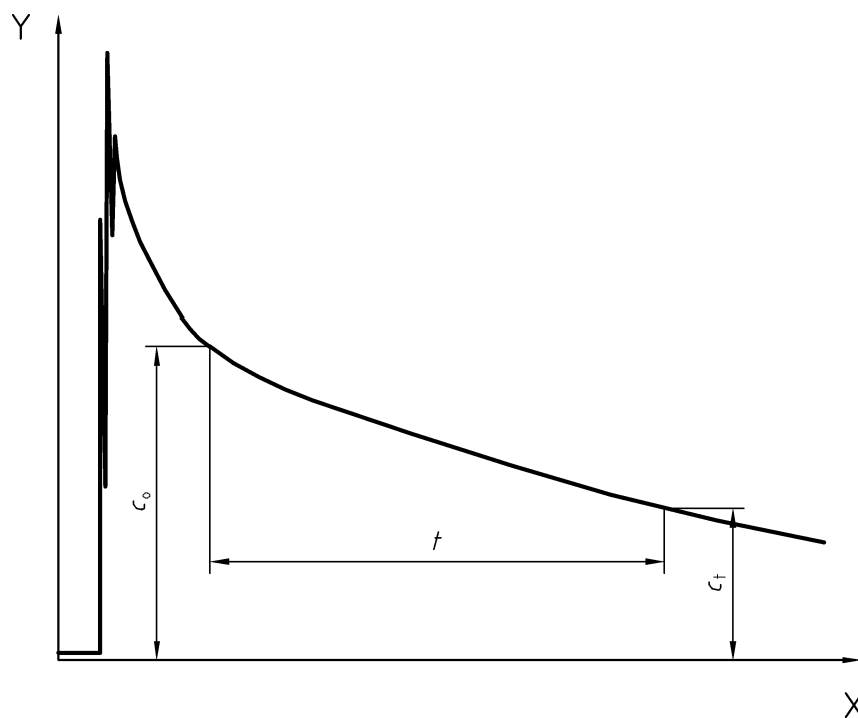

$$n = \frac{1}{t} \times \ln \frac{c_0}{c_t}$$

Key

Y N_2O concentration c

X Time t

Figure B.1 — Typical example of decrease in N_2O concentration versus time

Annex C (normative)

Determination of the steady-state emission value

C.1 Principle

The complete power function (see equation (C.1)) is used to determine the steady-state emission value by calculation:

$$c = A/(1 + Bt^D) \quad (\text{C.1})$$

where:

c is the chamber concentration, in milligrams per cubic metre;

t is the time, in hours; and

A , B and D are positive constants.

Best fits using this function unavoidably require some kind of regression algorithm for iterative least squares non-linear regression. These are commercially available for personal computers in a variety of software packages. All non-linear regression routines demand reasonable initial parameter estimates to achieve optimum convergence. Experience suggests the estimate for A should be 10 % to 20 % greater than the value of the first considered concentration value, whereas estimates of 0,1 for B and 0,5 for D are generally appropriate.

C.2 Determination of the steady-state emission value

For the determination of the steady-state emission-value, collect chamber data for at least 10 days (minimum of 14 values, preferably uniformly distributed in time). Then determine the values of the functional parameters in equation (C.1) (see Figure C.1) that provide the best fit to the data.

NOTE Descriptively equation (C.1) starts from $c = A$ when $t = 0$ and decreases to zero as t approaches infinity. It is in principle only capable of modelling monotonous decay processes. Therefore, to avoid bad fits, increased concentration data present at the start of the test, if any, should be removed from the data set.

For the verification of the steady-state use the following equation:

$$[(c_t - c_{t+96})/c_{t+96}] \leq \delta \quad (\text{C.2})$$

where:

c_t , c_{t+96} are formaldehyde concentrations calculated from equation (C.1) at times t and $t+96$ (i. e. four days (96 h) later);

t = 0, 24, 48, 72, 96, 120, 144, 168, 192, etc. are times in hours at which equation (C.2) shall be recursively evaluated;

δ is the acceptable decrease in concentration occurring over four days.

δ is fixed by this standard at 0,05 (5 %). The steady-state is reached at the first value of t which satisfies the equation (C.2). At this time the two concentrations can be regarded as quasi constant and the steady-state is assumed to be given by c_{t+96} . If δ is > 0,05, repeat the procedure after addition of data from further days of chamber testing and so on, until the conditions are fulfilled or the deadline of the test duration (28 days) is reached.

C.3 Exceptional feature

Equation (C.1) starts from $c = A$ for $t = 0$ and always decreases monotonously to zero as t approaches infinity. Therefore, the slope of the concentration c is always negative over the entire range of time. However, depending on the pattern of the initial data, equation (C.1) can assume two different shapes, dictated only by the size of parameter D . The first, much more common, occurs when the initial data decrease sharply, D being ≤ 1 . The second, less common occurs when the initial data decrease gently and D becomes > 1 .

In the first case the slope of the curve, absolute value, starts from infinity or from $A \cdot B$, depending on whether D is less than or equal to 1 when $t = 0$ and decreases continuously with time. In the second case, however, the curve exhibits an inflection point located at time t_i (see equation (C.3)):

$$t_i = \{(D - 1)/[B(c + 1)]\}^{1/D} \quad (\text{C.3})$$

and the slope of the curve now originates from zero, increases up to the inflection point and only after this does it decrease continuously (see Figure C.2).

Cases of $D \leq 1$ are unquestionably sound for equation (C.2), because the calculated difference between two consecutive formaldehyde concentrations measured at a given time apart (e. g., 96 h, as recommended in this standard) is initially the largest and becomes smaller and smaller with time. For $D > 1$, however, this only happens after the inflection point. As a consequence, particularly if the inflection point is located at a time later than 96 h, the small slope of equation (C.1) in the first testing days could result in equation (C.2) indicating an apparent, but false, steady-state in the first calculation. A reasonable way to surmount this difficulty would be that of identifying and then removing initially increasing concentration data via plot assistance. These data are those interfering a maximum in the plot and lying before it. Such a measure can remove a potential inflection point, or place it in a practically harmless position, i. e., close to the time axis origin. Simply neglecting the first 24 h data could, on the contrary, retain ill-suited values or, if data indicating the initial part of decay are excluded, could make it more difficult for the regression algorithm to converge smoothly with the curve parameters.

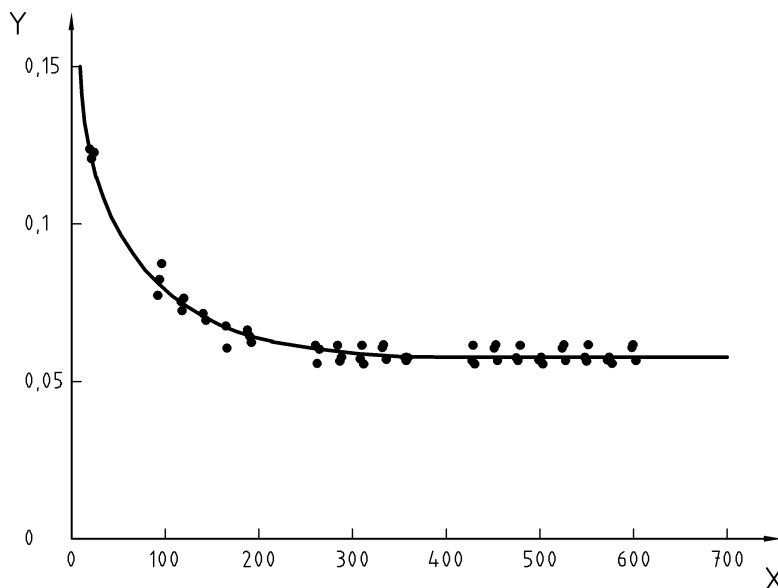

Key

Y Formaldehyde concentration c , in milligrams per cubic metre
X Time t , in hours

NOTE A, B, D are positive constants of the equation (C.1)
 r is the coefficient of correlation of the equation (C.1)

A = 0,185
B = 0,309
D = 0,335
 r = 0,988

Figure C.1 — Best fit of formaldehyde concentration data from a large chamber test on medium density fibreboards (MDF)

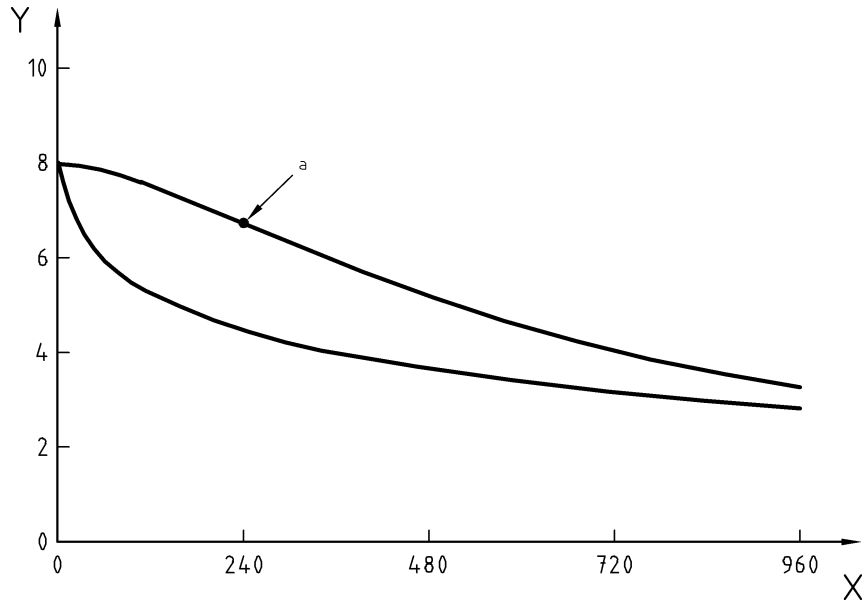

Upper curve: $D > 1$
Lower curve: $0 < D \leq 1$

Key

- Y Concentration (arbitrary units)
- X Duration of test, in hours
- ^a Inflection point

Figure C.2 — Dependence of concentration curve fitting upon the value of D

Annex D (informative)

Analytical procedure for the fluorimetric determination of formaldehyde content

D.1 Reagents

D.1.1 General

Reagents and water of recognised analytical purity are used for the analysis.

D.1.2 Acetylacetone solution

4 ml acetylacetone are added to a 1 000 ml volumetric flask and made up to the mark with water.

D.1.3 Ammonium acetate solution

200 g ammonium acetate are dissolved in water in a 1 000 ml volumetric flask and made up to the mark.

NOTE Commercially prepared solutions may be used.

D.2 Air sampling and analysis

Add 25 ml water to each of two gas washing bottles. Sample the air from the chamber by passing a minimum of 30 l, at a rate of approximately 1,5 l/min to 2,0 l/min through the gas washing bottles. Pipette 10 ml of each of the absorption solutions into a 50 ml flask and add 10 ml acetylacetone solution (see D.1.2) and 10 ml of ammonium acetate solution (see D.1.3). Heat the stoppered flasks for 15 min in a water bath at $(40 \pm 1) ^\circ\text{C}$. The solutions are then stored at room temperature for 1 h, protected against the influence of light. A blank value is determined in parallel, using a solution made up of 10 ml water, 10 ml acetylacetone solution and 10 ml ammonium acetate solution and is taken into consideration when calculating the formaldehyde content of the sample solution.

D.3 Equipment for chemical analysis

D.3.1 Fluorimetric spectrophotometer

D.3.2 Water bath, capable of maintaining a temperature of $(40 \pm 1) ^\circ\text{C}$

D.3.3 Volumetric flasks, 1000 ml (calibrated at $20 ^\circ\text{C}$)

D.3.4 Pipettes, 1 ml, 3 ml, 5 ml, 10 ml, 20 ml and 50 ml (calibrated at $20 ^\circ\text{C}$)

D.3.5 Volumetric flasks, 100 ml (calibrated at $20 ^\circ\text{C}$)

D.3.6 Flasks with stoppers (50 ml)

D.3.7 Balance, scale interval 0,1 mg

D.4 Calibration curve

D.4.1 General

The calibration curve is produced from a formaldehyde sodium bisulfite solution. This calibration curve is checked at least once a week.

D.4.2 Formaldehyde standard solution

Reagent: Formaldehyde sodium bisulfite

4,4703 g formaldehyde sodium bisulfite are dissolved in water in a 1 000 ml volumetric flask and made up to the mark with water. 1 ml of this solution contains 1 mg formaldehyde.

D.4.3 Formaldehyde calibration solution

Transfer 1 ml of the formaldehyde standard solution to a 1000 ml volumetric flask and made up to the mark with water. 1 ml of this calibration solution contains 1 μg formaldehyde.

D.4.4 Determination of the calibration curve

Pipette either 1 ml, 3 ml, 5 ml, 10 ml, 20 ml or 50 ml of the formaldehyde calibration solution (see D.4.3) into a 100 ml volumetric flask and made up to the mark with water.

10 ml of each are filled into a 50 ml flask and add 10 ml acetylacetone solution (see D.1.2) and 10 ml of ammonium acetate solution (see D.1.3). Heat the stoppered flasks for 15 min in a water bath at $(40 \pm 1) ^\circ\text{C}$. The solutions are then stored at room temperature for 1 h, protected against the influence of light. The fluorescence intensity is determined at a wavelength of excitation $\lambda_{\text{ex}} = 410 \text{ nm}$ and a wavelength of emission $\lambda_{\text{em}} = 510 \text{ nm}$. The intensity values are plotted against the formaldehyde concentrations between 0 $\mu\text{g}/\text{ml}$ and 1 $\mu\text{g}/\text{ml}$. The slope of the graph is either determined graphically or calculated.

D.5 Calculation of the amount of absorbed formaldehyde and calculation of the formaldehyde emission

See 9.5 and 9.6

Bibliography

- [1] CEC Project: Investigation on comparability of large chamber test for formaldehyde emission from wood based panels. Part I: Main programme. Wilhelm-Klauditz-Institute, Braunschweig, November 1992
- [2] CEC Project: Investigation on comparability of large chamber test for formaldehyde emission from wood based panels. Part II: Accompanying programme. Wilhelm-Klauditz-Institute, Braunschweig, December 1993
- [3] CEN Report CR 213: 'Particleboards — Determination of Formaldehyde Emission under Specified Conditions'.
- [4] Colombo, A.; Jann, O.; Marutzky, R.: The estimation of the steady state formaldehyde-concentration in large chambers. *Staub-Reinhaltung der Luft* 54 (1994), 143-146
- [5] COST Project 613: Indoor Air Quality and its Impact on Man. Report No. 2: Formaldehyde emission from wood based materials: Guideline for the determination of steady state concentrations in test chambers.
- [6] COST Project 613: Indoor Air Quality and its Impact on Man. Report No. 8: Guideline for the characterisation of volatile organic compounds emitted from indoor materials and products, using small test chambers.
- [7] Hoetjer, J. J.; Koerts, F.: A Model for Formaldehyde Release from Wood Products. In: CEN Report CR 213
- [8] NPA Formaldehyde test method — 2: Large Scale Test method for determining formaldehyde emissions from wood products: large chamber method FTM 2-1985, National Particleboard Association, Gaithersburg MA 198
- [9] Swedish Standard SS 270236: *Building boards — Determination of formaldehyde emission.*
- [10] ISO 16000-3, *Indoor air — Part 3: Determination of formaldehyde and other carbonyl compounds — Active sampling method.*

BSI — British Standards Institution

BSI is the independent national body responsible for preparing British Standards. It presents the UK view on standards in Europe and at the international level. It is incorporated by Royal Charter.

Revisions

British Standards are updated by amendment or revision. Users of British Standards should make sure that they possess the latest amendments or editions.

It is the constant aim of BSI to improve the quality of our products and services. We would be grateful if anyone finding an inaccuracy or ambiguity while using this British Standard would inform the Secretary of the technical committee responsible, the identity of which can be found on the inside front cover.
Tel: +44 (0)20 8996 9000. Fax: +44 (0)20 8996 7400.

BSI offers members an individual updating service called PLUS which ensures that subscribers automatically receive the latest editions of standards.

Buying standards

Orders for all BSI, international and foreign standards publications should be addressed to Customer Services. Tel: +44 (0)20 8996 9001.
Fax: +44 (0)20 8996 7001. Email: orders@bsi-global.com. Standards are also available from the BSI website at <http://www.bsi-global.com>.

In response to orders for international standards, it is BSI policy to supply the BSI implementation of those that have been published as British Standards, unless otherwise requested.

Information on standards

BSI provides a wide range of information on national, European and international standards through its Library and its Technical Help to Exporters Service. Various BSI electronic information services are also available which give details on all its products and services. Contact the Information Centre.
Tel: +44 (0)20 8996 7111. Fax: +44 (0)20 8996 7048. Email: info@bsi-global.com.

Subscribing members of BSI are kept up to date with standards developments and receive substantial discounts on the purchase price of standards. For details of these and other benefits contact Membership Administration.
Tel: +44 (0)20 8996 7002. Fax: +44 (0)20 8996 7001.
Email: membership@bsi-global.com.

Information regarding online access to British Standards via British Standards Online can be found at <http://www.bsi-global.com/bsonline>.

Further information about BSI is available on the BSI website at <http://www.bsi-global.com>.

Copyright

Copyright subsists in all BSI publications. BSI also holds the copyright, in the UK, of the publications of the international standardization bodies. Except as permitted under the Copyright, Designs and Patents Act 1988 no extract may be reproduced, stored in a retrieval system or transmitted in any form or by any means – electronic, photocopying, recording or otherwise – without prior written permission from BSI.

This does not preclude the free use, in the course of implementing the standard, of necessary details such as symbols, and size, type or grade designations. If these details are to be used for any other purpose than implementation then the prior written permission of BSI must be obtained.

Details and advice can be obtained from the Copyright & Licensing Manager.
Tel: +44 (0)20 8996 7070. Fax: +44 (0)20 8996 7553.
Email: copyright@bsi-global.com.